

LIGHTLIFT 20.10 *PERFORMANCE III S MK2*

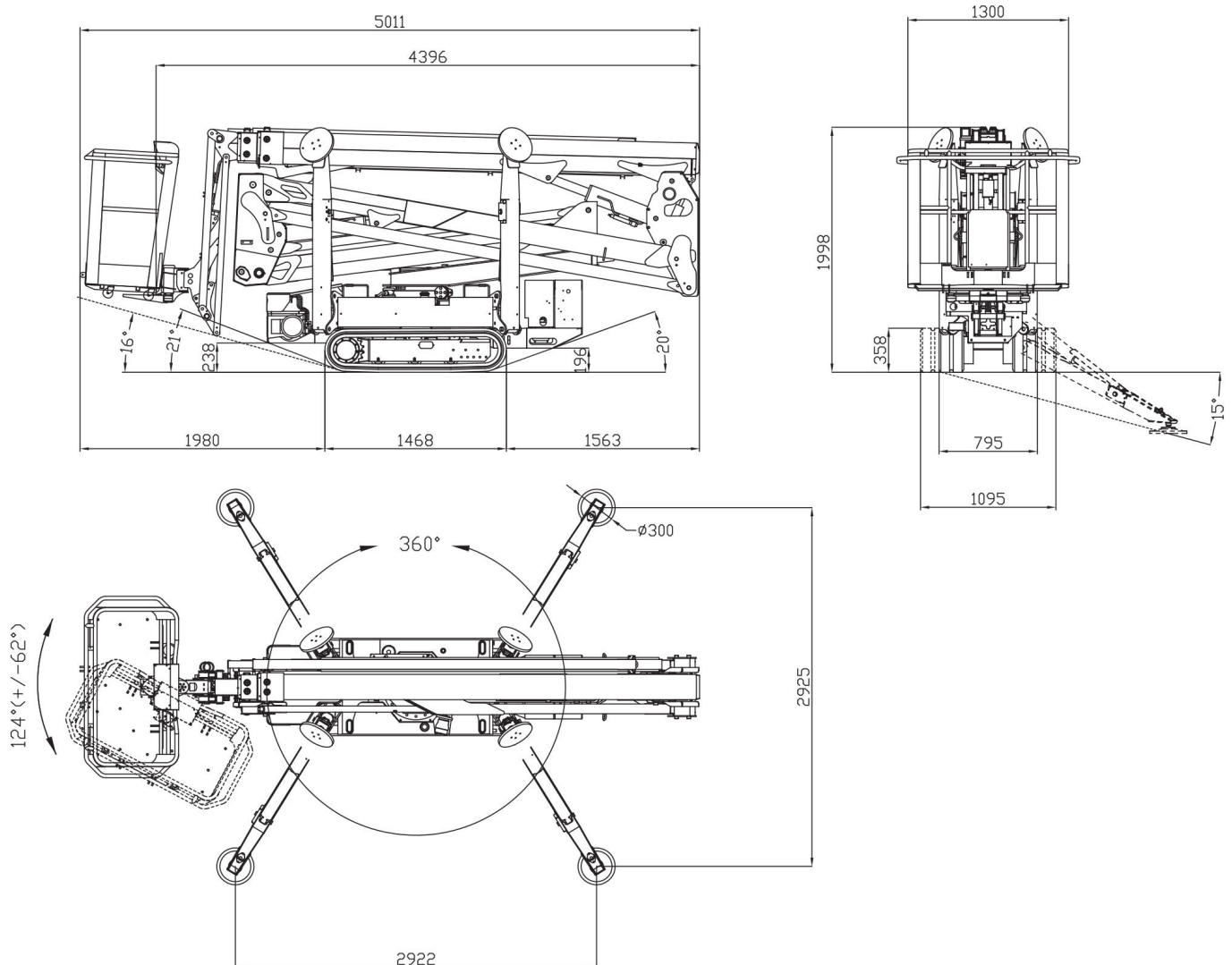

TRACKED AERIAL
PLATFORMS



LIGHTLIFT 20.10 *PERFORMANCE III S MK2*

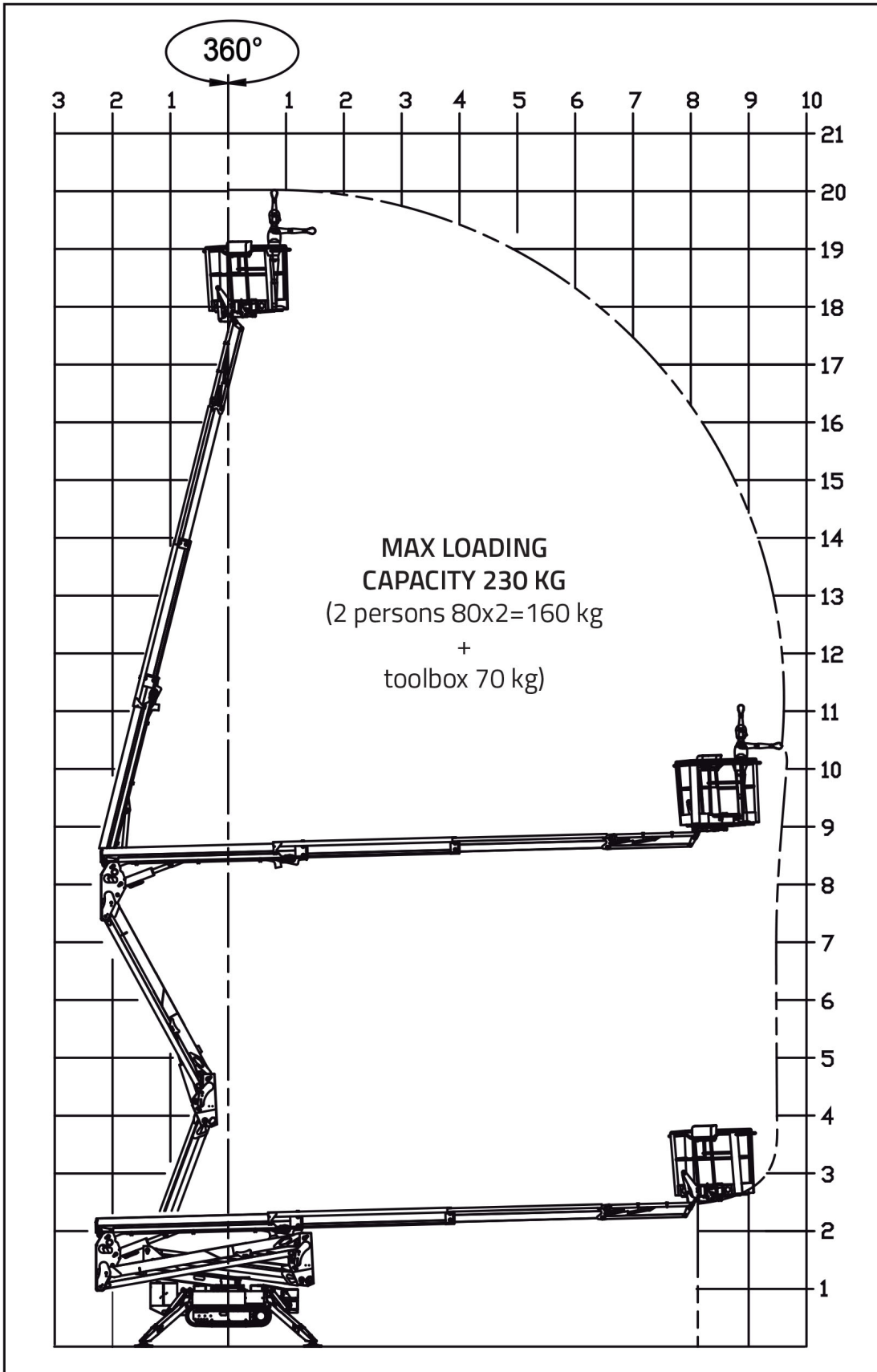

LIGHTLIFT 20.10 *PERFORMANCE III S MK2*

PETROL ENGINE

Brand HONDA
 Type iGX390
 Pistons no. and displacement single-cylinder 389 cm³
 Max. gross power 11,7 HP - 8,7kW @ 3600 rpm
 Electrical start 12 volt

DIESEL ENGINE

Brand KUBOTA
 Type Z602
 Pistons no. and displacement double-cylinder 599 cm³
 Max. gross power 14,5 HP - 10,8kW @ 3200 rpm
 Electrical start 12 volt

ELECTRIC MOTOR

Standard 230V / 50 Hz - 2,2 kW
 Optional 110V / 50 Hz - 2,2 kW

HYDRAULIC PUMPS

Pump engine no. 2 gear pumps
 Pump electric motor no. 2 gear pumps

TRACKED UNDERCARRIAGE

Track tensioner grease-filled
 Rollers no. per side 3 + slide
 Widening system 795 / 1095 mm
 Translation speed (petrol engine) with 2nd auto2speed 0,4 - 1,0 - 1,95 km/h
 Translation speed (diesel engine) with 2nd auto2speed 0,5 - 1,3 - 2,5 km/h

WEIGHT MACHINE (petrol engine) 2840 kg
 WEIGHT MACHINE (diesel engine) 2940 kg

FUEL TANK (petrol engine) 5,3 liters
 FUEL TANK (diesel engine) 11 liters

MAX UPPER SLANT 16° / 28,7%
 MAX WIND SPEED 12,5 m/s

LIGHTLIFT 20.10 PERFORMANCE III S MK2



ELECTRIC SYSTEM - LITHIUM ION

Electric system voltage	72V-12V
Lithium battery pack	7,2 KWh
Autonomy (continuous cycle)*	4-5 h
Onboard battery charger	220V 50Hz
Optional battery charger	110V 50Hz
Recharge time on flat batteries	4 h (indicative)
Recharge time to 80% on flat batteries	2 h (indicative)

HYDRAULIC PUMPS

Electric motor	no.2 gear pumps
----------------------	-----------------

TRACKED UNDERCARRIAGE

Track tensioner	grease-filled
Rollers no. per side	3 + slide
Widening system	795 / 1095 mm
Translation speed	0,83 - 1,6 km/h

WEIGHT MACHINE	2950 kg
MAX UPPER SLANT	16° / 28,7%
MAX WIND SPEED	12,5 m/s

* (Autonomy measured with Hinowa H2 operating cycle)